

NK-30

Service Workshop Hose Crimper max. 1.1/4" 4-SP

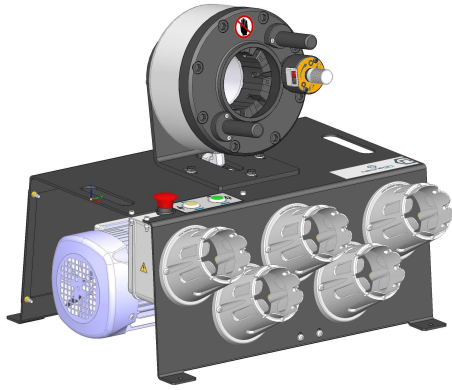

Multipurpose and Universal Workshop crimper

The use of this machine is ideally recommended for service hose assembly up to 1 1/4"-4-Wire spiral.

The capacity of this machine covers the most widely used hoses on the market and thanks to its large opening you can pass 2 x 90 deg. elbows with BSP nut up to 1 1/4".

We recommend the use of this machine for an intermittent use of approximately 50 to 100 hose assemblies per day

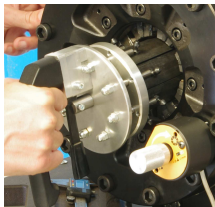

Option : QCT-NLS

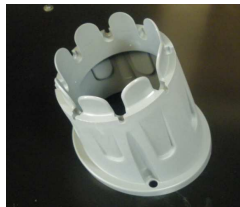

Option : PDR-1



Option : WP-12PDR

Technical Description NK-30	
Maximum capacity : <i>For an intermittent use in high pressure hose assembling</i>	2-SN : 1 1/2" (DN32; -20) 4-SP : 1 1/4" (DN32, -20) 6-SP or Interlock : 1" (DN25, -16)
Motor	2.2 kW - 400V 3-PH 50hz (NK30P.1) 2.2 kW - 230V 1-PH 50Hz (NK30P.3)
Radial Press force	135 Tons
Opening with dies	Ø Die + 28mm (Press path : +12mm)
Opening without dies	98mm
Length of Master Die shoes	75mm
Die sizes available	Ø6,8,10,12,15*,18*,21*,24*,27*,30,33*,39*,45,48*,51,57 * size included in standard Die Pack - 8 sets NK30
Dimension of the machine	Width : 800mm x Depth : 440mm x Height : 670mm
Options available	<ul style="list-style-type: none"> • Quick Change Tool (QCT-NLS) • Individual Die Storage Rack (PDR-1) • Die Storage Panel (WP-12PDR) • Foot Switch (FS)
Net Weight	70 kgs (with oil, w/o dies)
Transport Packing details	Each machine on wood crate (NIMP15 conform) Packing dimensions : 58x70x75cms, 105 kgs (with 8 sets of dies)